



ГОСУДАРСТВЕННЫЙ СТАНДАРТ СОЮЗА ССР

ДЕТАЛИ ТРУБОПРОВОДОВ
СТАЛЬНЫЕ БЕСШОВНЫЕ ПРИВАРНЫЕ
НА $P_y \leq 10$ МПа (≤ 100 кгс/см²)

ТРОЙНИКИ

КОНСТРУКЦИЯ И РАЗМЕРЫ

ГОСТ 17376-83

ГОСУДАРСТВЕННЫЙ КОМИТЕТ СССР ПО СТАНДАРТАМ

Москва

ГОСУДАРСТВЕННЫЙ СТАНДАРТ СОЮЗА ССР

ДЕТАЛИ ТРУБОПРОВОДОВ СТАЛЬНЫЕ БЕСШОВНЫЕ
ПРИВАРНЫЕ НА $P_y \leq 10$ МПа (≤ 100 кгс/см²)

ТРОЙНИКИ

Конструкция и размеры

Seamless welded steel pipeline components
for $P_n \leq 10$ МПа (≤ 100 kgf/cm²).
Tees. Design and dimensions

ГОСТ
17376-83*

Взамен
ГОСТ 17376-77

Постановлением Государственного комитета СССР по стандартам от 19 декабря 1983 г. № 6711 срок действия установлен

с 01.01.85
до 01.01.90

** Переиздание (июль 1986 г.) с Изменением № 1,
утвержденным в декабре 1984 г.; Пост. № 4187 от 10.12.84 (ИУС № 3-85, 4-86).*

Изменение № 2 ГОСТ 17376-83 Детали трубопроводов стальные бесшовные приварные на $P_y \leq 10$ МПа (≤ 100 кгс/см²). Тройники. Конструкция и размеры

Утверждено и введено в действие Постановлением Государственного комитета СССР по стандартам от 22.06.89 № 1870

Дата введения 01.01.90

1. Настоящий стандарт распространяется на стальные бесшовные приварные равнопроходные и переходные тройники на $P_y \leq 10$ МПа (≤ 100 кгс/см²).
2. Основные параметры тройников - по [ГОСТ 17380-83](#).

(Измененная редакция, Изм. № 2).

3. Конструкция и размеры тройников должны соответствовать указанным на [чертеже](#) и в [таблице](#).

Равнопроходный тройник

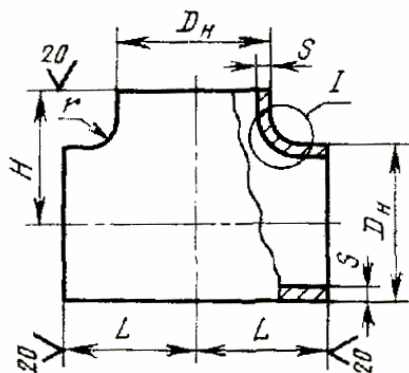

Переходный тройник

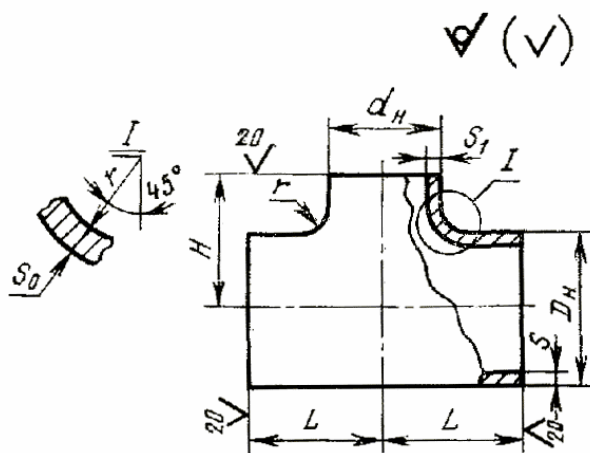

Размеры, мм

| Условный проход | | Наружный диаметр | | L | H | s | s ₁ | s ₀ | r ^{**} , не более | Условное давление P _y , МПа (≈ кгс/см ²), не более | | | Масса, кг, не более | |
|-----------------|----------------|------------------|----------------|------------|------------|-----|----------------|----------------|----------------------------|---|-------------------|--------------------|---------------------|-----|
| D _y | d _y | D _n | d _n | | | | | | | Транспортируемые вещества | | | | |
| | | | | | | | | | | неагрессивные | среднеагрессивные | пар и горячая вода | | |
| 40 | - | 45 | - | 40 | 40 | 2,5 | - | 2,5 | 12,5 | 10,0 (100) | 2,5 (25) | 6,3 (63) | 0,5 | |
| | | | | | | 4,0 | - | 4,0 | | 10,0 (100) | 10,0 (100) | 10,0 (100) | 0,7 | |
| 50 | - | 57 | - | 50 | 45 | 3,0 | - | | | 10,0 (100) | 4,0 (40) | 6,3 (63) | 0,8 | |
| | | | | | | 5,0 | - | | | 10,0 (100)* | 10,0 (100) | 10,0 (100) | 1,0 | |
| | | | | | | 3,0 | 2,5 | 3,0 | | 10,0 (100) | 6,3 (63) | 6,3 (63) | 0,7 | |
| | | | | | | 5,0 | 4,0 | 5,0 | | 10,0 (100)* | 10,0 (100) | 10,0 (100) | 1,0 | |
| 65 | - | 76 | - | 65 | 60 | 3,5 | - | 3,5 | | 17,0 | 6,3 (63) | 4,0 (40) | 4,0 (40) | 1,5 |
| | | | | | | 6,0 | - | 6,0 | | | 10,0 (100) | 10,0 (100) | 10,0 (100) | 2,3 |
| | | | | | | 3,5 | 3,0 | 3,5 | | | 6,3 (63) | 4,0 (40) | 4,0 (40) | 1,6 |
| | | | | | | 6,0 | 5,0 | 6,0 | | | 10,0 (100) | 10,0 (100) | 10,0 (100) | 2,4 |
| | | | | | | 3,5 | 2,5 | 3,5 | | | 6,3 (63) | 4,0 (40) | 4,0 (40) | 1,5 |
| | | | | | | 6,0 | 4,0 | 6,0 | | | 10,0 (100) | 10,0 (100) | 10,0 (100) | 2,3 |
| 80 | - | 89 | - | 80 | 70 | 3,5 | - | 3,5 | 20,0 | | 6,3 (63) | 2,5 (25) | 4,0 (40) | 2,6 |
| | | | | | | 6,0 | - | 6,0 | | | 10,0 (100) | 10,0 (100) | 10,0 (100) | 3,7 |
| | | | | | | 3,5 | 3,5 | 3,5 | | | 6,3 (63) | 2,5 (25) | 4,0 (40) | 2,2 |
| | | | | | | 6,0 | 6,0 | 6,0 | | | 10,0 (100) | 10,0 (100) | 10,0 (100) | 3,2 |
| | | | | | | 3,5 | 3,0 | 3,5 | | | 6,3 (63) | 4,0 (40) | 4,0 (40) | 1,9 |
| | | | | | | 6,0 | 4,0 | 6,0 | | | 10,0 (100) | 10,0 (100) | 10,0 (100) | 2,8 |
| 100 | - | 108 | - | 100 | 80 | 4,0 | - | 4,0 | | 20,0 | 6,3 (63) | 4,0 (40) | 4,0 (40) | 3,2 |
| | | | | | | 6,0 | - | 6,0 | | | 10,0 (100) | 6,3 (63) | 6,3 (63) | 5,5 |
| | | | | | | 8,0 | - | 8,0 | | | 10,0 (100)* | 10,0 (100) | 10,0 (100) | 7,3 |
| | | | | | | 4,0 | 4,0 | 4,0 | | | 6,3 (63) | 4,0 (40) | 4,0 (40) | 3,1 |
| | | | | | | 6,0 | 6,0 | 6,0 | | | 10,0 (100) | 6,3 (63) | 6,3 (63) | 4,7 |
| | | | | | | 8,0 | 8,0 | 8,0 | | | 10,0 (100)* | 10,0 (100) | 10,0 (100) | 6,3 |
| | | | | | | 4,0 | 3,5 | 4,0 | 6,3 (63) | | 4,0 (40) | 4,0 (40) | 3,1 | |
| | | | | | | 6,0 | 5,0 | 6,0 | 8,0 (80) | | 6,3 (63) | 6,3 (63) | 4,5 | |
| | | | | | | 8,0 | 8,0 | 8,0 | 10,0 (100)* | | 10,0 (100) | 10,0 (100) | 6,0 | |
| | | | | | | 125 | - | 133 | - | | 110 | 95 | 4,0 | - |
| 6,0 | - | 6,0 | 8,0 (80) | 6,3 (63) | 4,0 (40) | | | | | | | | 7,0 | |
| 8,0 | - | 9,0 | 10,0 (100) | 10,0 (100) | 10,0 (100) | | | | | | | | 9,4 | |
| 4,0 | 4,0 | 4,0 | 6,3 (63) | 2,5 (25) | 2,5 (25) | | | | | 4,1 | | | | |
| 100 | 100 | | | | | | | | | | | | | |

| Условный проход | | Наружный диаметр | | L | H | s | s ₁ | s ₀ | r ^{**} , не более | Условное давление P _y , МПа (≈ кгс/см ²), не более | | | Масса, кг, не более |
|-----------------|----------------|------------------|----------------|---------------|-------------------|--------------------|----------------|----------------|----------------------------|---|------------|------------|---------------------|
| D _y | d _y | D _n | d _n | | | | | | | Транспортируемые вещества | | | |
| | | | | неагрессивные | среднеагрессивные | пар и горячая вода | | | | | | | |
| 150 | 80 | 159 | 89 | 130 | 110 | 6,0 | 5,0 | 6,0 | 25 | 8,0 (80) | 6,3 (63) | 4,0 (40) | 7,1 |
| | | | | | | 8,0 | 6,0 | 9,0 | | 10,0 (100) | 10,0 (100) | 10,0 (100) | 9,4 |
| | | | | | | 4,0 | 3,5 | 4,0 | | 6,3 (63) | 2,5 (25) | 2,5 (25) | 3,8 |
| | | | | | | 6,0 | 5,0 | 6,0 | | 8,0 (80) | 6,3 (63) | 4,0 (40) | 7,2 |
| | | | | | | 8,0 | 6,0 | 9,0 | | 10,0 (100) | 10,0 (100) | 10,0 (100) | 9,6 |
| | | | | | | 4,5 | - | 4,5 | | 4,0 (40) | 2,5 (25) | 2,5 (25) | 6,5 |
| | 6,0 | - | 6,0 | 6,3 (63) | 4,0 (40) | 4,0 (40) | 9,0 | | | | | | |
| | 8,0 | - | 9,0 | 10,0 (100) | 8,0 (80) | 6,3 (63) | 11,9 | | | | | | |
| | 4,5 | 4,0 | 4,5 | 4,0 (40) | 2,5 (25) | 2,5 (25) | 6,1 | | | | | | |
| | 6,0 | 5,0 | 6,0 | 6,3 (63) | 4,0 (40) | 4,0 (40) | 9,3 | | | | | | |
| | 8,0 | 6,0 | 9,0 | 10,0 (100) | 8,0 (80) | 6,3 (63) | 12,2 | | | | | | |
| | 4,5 | 4,0 | 4,5 | 4,0 (40) | 2,5 (25) | 2,5 (25) | 6,0 | | | | | | |
| 6,0 | 4,0 | 6,0 | 6,3 (63) | 4,0 (40) | 4,0 (40) | 9,5 | | | | | | | |
| 8,0 | 5,0 | 9,0 | 10,0 (100) | 8,0 (80) | 6,3 (63) | 14,2 | | | | | | | |
| 200 | 150 | 219 | 159 | 160 | 140 | 6,0 | - | 6,0 | 25 | 4,0 (40) | 2,5 (25) | 2,5 (25) | 13,5 |
| | | | | | | 8,0 | - | 8,0 | | 6,3 (63) | 4,0 (40) | 4,0 (40) | 16,4 |
| | | | | | | 10,0 | - | 12,0 | | 10,0 (100) | 8,0 (80) | 6,3 (63) | 21,2 |
| | | | | | | 6,0 | 4,5 | 6,0 | | 4,0 (40) | 2,5 (25) | 2,5 (25) | 13,2 |
| | | | | | | 8,0 | 6,0 | 8,0 | | 6,3 (63) | 4,0 (40) | 4,0 (40) | 18,7 |
| | | | | | | 10,0 | 8,0 | 12,0 | | 10,0 (100) | 8,0 (80) | 6,3 (63) | 20,3 |
| | 6,0 | 4,0 | 6,0 | 4,0 (40) | 2,5 (25) | 2,5 (25) | 13,7 | | | | | | |
| | 8,0 | 5,0 | 8,0 | 6,3 (63) | 4,0 (40) | 4,0 (40) | 20,0 | | | | | | |
| | 10,0 | 8,0 | 12,0 | 10,0 (100) | 8,0 (80) | 6,3 (63) | 23,7 | | | | | | |
| | 8,0 | - | 8,0 | 4,0 (40) | 4,0 (40) | 2,5 (25) | 31,3 | | | | | | |
| | 10,0 | - | 10,0 | 6,3 (63) | 6,3 (63) | 4,0 (40) | 36,0 | | | | | | |
| | 12,0 | - | 15,0 | 10,0 (100) | 10,0 (100) | 6,3 (63) | 40,9 | | | | | | |
| 8,0 | 6,0 | 8,0 | 6,3 (63) | 4,0 (40) | 2,5 (25) | 27,6 | | | | | | | |
| 10,0 | 8,0 | 10,0 | 8,0 (80) | 6,3 (63) | 4,0 (40) | 32,9 | | | | | | | |
| 12,0 | 10,0 | 15,0 | 10,0 (100) | 10,0 (100) | 6,3 (63) | 43,3 | | | | | | | |
| 8,0 | 4,5 | 8,0 | 6,3 (63) | 4,0 (40) | 2,5 (25) | 23,1 | | | | | | | |
| 10,0 | 6,0 | 10,0 | 8,0 (80) | 6,3 (63) | 4,0 (40) | 28,5 | | | | | | | |
| 12,0 | 8,0 | 15,0 | 10,0 (100) | 10,0 (100) | 6,3 (63) | 44,8 | | | | | | | |
| 300 | - | 325 | - | 220 | 200 | 8,0 | - | 8,0 | 25 | 4,0 (40) | 2,5 (25) | 2,5 (25) | 40,1 |

| Условный проход | | Наружный диаметр | | L | H | s | s ₁ | s ₀ | r **, не более | Условное давление P _y , МПа (≈ кгс/см ²), не более | | | Масса, кг, не более |
|-----------------|----------------|------------------|----------------|-----|-----|------|----------------|----------------|----------------|---|----------|----------|---------------------|
| D _y | d _y | D _n | d _n | | | | | | | Транспортируемые вещества | | | |
| | 250 | 377 | 273 | 240 | 225 | 10,0 | - | 12,0 | | 6,3 (63) | 6,3 (63) | 4,0 (40) | 46,0 |
| | | | | | | 12,0 | - | 16,0 | | 10,0 (100) | 8,0 (80) | 6,3 (63) | 53,0 |
| | | | | | | 8,0 | 7,0 | 8,0 | | 4,0 (40) | 4,0 (40) | 2,5 (25) | 35,6 |
| | 10,0 | | 10,0 | | | 12,0 | 6,3 (63) | 6,3 (63) | | 4,0 (40) | 45,7 | | |
| | 12,0 | | 10,0 | | | 16,0 | 10,0 (100) | 8,0 (80) | | 6,3 (63) | 55,9 | | |
| | 200 | | 219 | | | 8,0 | 6,0 | 8,0 | | 4,0 (40) | 4,0 (40) | 2,5 (25) | 38,0 |
| 350 | 300 | 377 | 325 | 240 | 225 | 10,0 | - | 12,0 | | 4,0 (40) | 2,5 (25) | 2,5 (25) | 53,5 |
| | | | | | | 12,0 | - | 18,0 | | 10,0 (100) | 8,0 (80) | 6,3 (63) | 73,3 |
| | | | | | | 9,0 | 8,0 | 9,0 | | 4,0 (40) | 4,0 (40) | 2,5 (25) | 53,9 |
| | 12,0 | | 10,0 | | | 18,0 | 10,0 (100) | 8,0 (80) | | 6,3 (63) | 79,5 | | |
| | 9,0 | | 8,0 | | | 9,0 | 4,0 (40) | 4,0 (40) | | 2,5 (25) | 55,5 | | |
| | 12,0 | | 10,0 | | | 18,0 | 10,0 (100) | 8,0 (80) | | 6,3 (63) | 82,0 | | |
| 400 | 350 | 426 | 377 | 270 | 250 | 10,0 | - | 12,0 | | 4,0 (40) | 4,0 (40) | 2,5 (25) | 75,5 |
| | | | | | | 16,0 | - | 20,0 | | 10,0 (100) | 8,0 (80) | 4,0 (40) | 105,9 |
| | | | | | | 10,0 | 9,0 | 12,0 | | 4,0 (40) | 4,0 (40) | 2,5 (25) | 67,7 |
| | 16,0 | | 12,0 | | | 20,0 | 10,0 (100) | 8,0 (80) | | 4,0 (40) | 111,0 | | |
| | 10,0 | | 8,0 | | | 12,0 | 4,0 (40) | 4,0 (40) | | 2,5 (25) | 70,7 | | |
| | 16,0 | | 10,0 | | | 20,0 | 10,0 (100) | 8,0 (80) | | 4,0 (40) | 114,7 | | |

* Для условий эксплуатации, указанных в п. 1.1г ГОСТ 17380-83.

** Радиус r должен быть не менее s.

Примечания:

1. Условные давления, указанные в графе «пар и горячая вода», относятся только к деталям трубопроводов, на которые распространяются «Правила устройства и безопасной эксплуатации трубопроводов пара и горячей воды» Госгортехнадзора СССР.

2. (Исключен, Изм. № 2).

3. Масса указана для справок.

(Измененная редакция, Изм. № 2).

Пример условного обозначения равнопроходного тройника $D_n = 325$ мм, $s = 10$ мм из стали 20:

Тройник 325×10 ГОСТ 17376-83.

То же, из стали 10Г2:

Тройник 325×10 - 10 Г2 ГОСТ 17376-83.

То же, переходного тройника $D_n = 325$ мм, $d_n = 273$ мм, $s = 12$ мм, $s_1 = 10$ мм из стали 20:

Тройник 325×12 - 273×10 ГОСТ 17376-83.

То же, из стали 09Г2С:

Тройник 325×12 - 273×10 - 09Г2С ГОСТ 17376-83.

То же, из стали 20 для трубопроводов пара, и горячей воды:

Тройник П 325×12-273×10 ГОСТ 17376-83.

4. Технические требования - по ГОСТ 17380-83.

5. Коды ОКП приведены в справочном [приложении](#).

ПРИЛОЖЕНИЕ
Справочное

КОДЫ ОКП

1. Коды ОКП тройников для неагрессивных и среднеагрессивных сред должны соответствовать указанным в [табл. 1](#).

Таблица 1

| Обозначение отводов | | Коды ОКП тройников из стали | | | | | |
|---------------------------|--------------|-----------------------------|--------------|--------------|--------------|--------------|----|
| | | 20 | | 10Г2 | | 09Г2С | |
| | | Код ОКП | КЧ | Код ОКП | КЧ | Код ОКП | КЧ |
| Тройник равнопроходный | 45×2,5 | 14 6821 0100 | 06 | 14 6821 4000 | 04 | 14 6821 4700 | 05 |
| | 45×4,0 | 14 6821 0102 | 04 | 14 6821 4002 | 02 | 14 6821 4702 | 03 |
| | 57×3,0; | 14 6821 0104 | 02 | 14 6821 4004 | 00 | 14 6821 4704 | 01 |
| | 57×5,0 | 14 6821 0106 | 00 | 14 6821 4006 | 09 | 14 6821 4706 | 06 |
| | 76×3,5 | 14 6821 0108 | 09 | 14 6821 4008 | 07 | 14 6821 4708 | 08 |
| | 76×6,0 | 14 6821 0110 | 04 | 14 6821 4010 | 02 | 14 6821 4710 | 03 |
| | 89×3,5 | 14 6821 0112 | 02 | 14 6821 4012 | 00 | 14 6821 4712 | 01 |
| | 89×6,0 | 14 6821 0114 | 00 | 14 6821 4014 | 09 | 14 6821 4714 | 03 |
| | 108×4,0 | 14 6821 0116 | 09 | 14 6821 4016 | 07 | 14 6821 4716 | 08 |
| | 108×6,0 | 14 6821 0118 | 07 | 14 6821 4018 | 05 | 14 6821 4718 | 06 |
| | 108×8,0 | 14 6821 0119 | 06 | 14 6821 4019 | 04 | 14 6821 4719 | 05 |
| | 133×4,0 | 14 6821 0120 | 02 | 14 6821 4020 | 00 | 14 6821 4720 | 01 |
| | 133×6,0 | 14 6821 0122 | 00 | 14 6821 4022 | 09 | 14 6821 4722 | 00 |
| | 133×8,0 | 14 6821 0123 | 10 | 14 6821 4023 | 08 | 14 6821 4723 | 09 |
| | 159×4,5 | 14 6821 0124 | 09 | 14 6821 4024 | 07 | 14 6821 4724 | 08 |
| | 159×6,0 | 14 6821 0126 | 07 | 14 6821 4026 | 05 | 14 6821 4726 | 06 |
| | 159×8,0 | 14 6821 0128 | 05 | 14 6821 4028 | 03 | 14 6821 4728 | 04 |
| | 219×6,0 | 14 6821 0130 | 00 | 14 6821 4030 | 09 | 14 6821 4730 | 08 |
| | 219×8,0 | 14 6821 0132 | 09 | 14 6821 4032 | 07 | 14 6821 4732 | 08 |
| | 219×10,0 | 14 6821 0134 | 07 | 14 6821 4034 | 05 | 14 6821 4734 | 06 |
| | 273×8,0 | 14 6821 0136 | 05 | 14 6821 4036 | 03 | 14 6821 4736 | 04 |
| | 273×10,0 | 14 6821 0138 | 03 | 14 6821 4038 | 01 | 14 6821 4738 | 02 |
| | 273×12,0 | 14 6821 0140 | 09 | 14 6821 4040 | 07 | 14 6821 4740 | 08 |
| | 325×8,0 | 14 6821 0142 | 07 | 14 6821 4042 | 05 | 14 6821 4742 | 06 |
| | 325×10,0 | 14 6821 0144 | 05 | 14 6821 4044 | 03 | 14 6821 4744 | 04 |
| | 325×12,0 | 14 6821 0146 | 03 | 14 6821 4046 | 01 | 14 6821 4746 | 02 |
| | 377×9,0 | 14 6821 0148 | 01 | 14 6821 4048 | 00 | 14 6821 4748 | 00 |
| 377×12,0 | 14 6821 0150 | 07 | 14 6821 4050 | 05 | 14 6821 4750 | 06 | |
| 426×10,0 | 14 6821 0152 | 05 | 14 6821 4062 | 03 | 14 6821 4752 | 02 | |

| Обозначение отводов | | Коды ОКП тройников из стали | | | | | |
|-----------------------|-------------------|-----------------------------|--------------|--------------|--------------|--------------|----|
| | | 20 | | 10Г2 | | 09Г2С | |
| | | Код ОКП | КЧ | Код ОКП | КЧ | Код ОКП | КЧ |
| | 426×16,0 | 14 6821 0154 | 03 | 14 6821 4054 | 01 | 14 6821 4754 | 06 |
| Тройник переходный | 57×3,0-45×2,5 | 14 6821 0500 | 05 | 14 6821 4500 | 00 | 14 6821 4800 | 02 |
| | 57×5,0-45×4,0 | 14 6821 0502 | 03 | 14 6821 4502 | 09 | 14 6821 4802 | 00 |
| | 76×3,5-57×3,0 | 14 6821 0504 | 01 | 14 6821 4504 | 07 | 14 6821 4804 | 09 |
| | 76×6,0-57×5,0 | 14 6821 0506 | 05 | 14 6821 4506 | 05 | 14 6821 4803 | 10 |
| | 76×3,5-45×2,5 | 14 6821 0508 | 08 | 14 6821 4508 | 03 | 14 6821 4808 | 05 |
| | 76×6,0-45×4,0 | 14 6821 0510 | 03 | 14 6821 4510 | 09 | 14 6821 4810 | 00 |
| | 89×3,5-76×3,5 | 14 6821 0512 | 01 | 14 6821 4512 | 07 | 14 6821 4812 | 09 |
| | 89×6,0-76×6,0 | 14 6821 0514 | 02 | 14 6821 4514 | 05 | 14 6821 4814 | 07 |
| | 89×3,5-57×3,0 | 14 6821 0516 | 08 | 14 6821 4516 | 03 | 14 6821 4816 | 05 |
| | 89×6,0-57×4,0 | 14 6821 0518 | 06 | 14 6821 4518 | 01 | 14 6821 4818 | 03 |
| | 108×4,0-89×4,0 | 14 6821 0520 | 01 | 14 6821 4520 | 07 | 14 6821 4820 | 09 |
| | 108×6,0-89×6,0 | 14 6821 0522 | 00 | 14 6821 4522 | 05 | 14 6821 4822 | 07 |
| | 108×8,0-89×8,0 | 14 6821 0523 | 09 | 14 6821 4523 | 04 | 14 6821 4823 | 06 |
| | 108×4,0-76×3,5 | 14 6821 0524 | 08 | 14 6821 4524 | 03 | 14 6821 4824 | 05 |
| | 108×6,0-76×5,0 | 14 6821 0526 | 06 | 14 6821 4526 | 01 | 14 6821 4826 | 03 |
| | 108×8,0-76×8,0 | 14 6821 0527 | 05 | 14 6821 4527 | 00 | 14 6821 4827 | 02 |
| | 133×4,0-108×4,0 | 14 6821 0528 | 04 | 14 6821 4528 | 03 | 14 6821 4828 | 01 |
| | 133×6,0-108×5,0 | 14 6821 0530 | 07 | 14 6821 4530 | 05 | 14 6821 4830 | 07 |
| | 133×8,0-108×6,0 | 14 6821 0531 | 09 | 14 6821 4531 | 04 | 14 6821 4831 | 06 |
| | 133×4,0-89×3,5 | 14 6821 0532 | 08 | 14 6821 4532 | 03 | 14 6821 4832 | 05 |
| | 133×6,0-89×5,0 | 14 6821 0534 | 06 | 14 6821 4534 | 01 | 14 6821 4834 | 03 |
| | 133×8,0-89×6,0 | 14 6821 0535 | 05 | 14 6821 4535 | 00 | 14 6821 4835 | 02 |
| | 159×4,5-133×4,0 | 14 6821 0536 | 04 | 14 6821 4536 | 00 | 14 6821 4836 | 01 |
| | 159×6,0-133×5,0 | 14 6821 0538 | 02 | 14 6821 4538 | 08 | 14 6821 4838 | 10 |
| | 159×8,0-133×6,0 | 14 6821 0540 | 08 | 14 6821 4540 | 03 | 14 6821 4840 | 05 |
| | 159×4,5-108×4,0 | 14 6821 0542 | 06 | 14 6821 4542 | 01 | 14 6821 4842 | 03 |
| | 159×6,0-108×4,0 | 14 6821 0544 | 04 | 14 6821 4544 | 08 | 14 6821 4844 | 01 |
| | 159×8,0-108×5,0 | 14 6821 0546 | 02 | 14 6821 4546 | 08 | 14 6821 4846 | 09 |
| | 219×6,0-159×4,5 | 14 6821 0548 | 00 | 14 6821 4548 | 06 | 14 6821 4848 | 08 |
| | 219×8,0-159×6,0 | 14 6821 0550 | 06 | 14 6821 4550 | 01 | 14 6821 4850 | 03 |
| | 219×10,0-169×8,0 | 14 6821 0552 | 04 | 14 6821 4552 | 05 | 14 6821 4852 | 01 |
| | 219×6,0-133×4,0 | 14 6821 0554 | 02 | 14 6821 4554 | 08 | 14 6821 4854 | 06 |
| | 219×8,0-133×5,0 | 14 6821 0556 | 00 | 14 6821 4556 | 06 | 14 6821 4856 | 08 |
| | 219×10,0-133×8,0 | 14 6821 0558 | 09 | 14 6821 4558 | 04 | 14 6821 4858 | 06 |
| | 273×8,0-219×6,0 | 14 6821 0560 | 04 | 14 6821 4560 | 02 | 14 6821 4860 | 01 |
| | 273×10,0-219×8,0 | 14 6821 0562 | 02 | 14 6821 4562 | 08 | 14 6821 4862 | 03 |
| | 273×12,0-219×10,0 | 14 6821 0564 | 00 | 14 6821 4564 | 06 | 14 6821 4864 | 08 |
| | 273×8,0-159×4,5 | 14 6821 0566 | 09 | 14 6821 4566 | 04 | 14 6821 4866 | 06 |
| | 273×10,0-159×6,0 | 14 6821 0668 | 07 | 14 6821 4568 | 02 | 14 6821 4868 | 04 |
| | 273×12,0-159×8,0 | 14 6821 0570 | 02 | 14 6821 4570 | 08 | 14 6821 4870 | 00 |
| | 325×8,0-273×7,0 | 14 6821 0572 | 00 | 14 6821 4572 | 06 | 14 6821 4871 | 09 |
| | 325×10,0-273×10,0 | 14 6821 0574 | 09 | 14 6821 4574 | 04 | 14 6821 4874 | 06 |
| | 325×12,0-273×10,0 | 14 6821 0576 | 07 | 14 6821 4576 | 02 | 14 6821 4876 | 04 |
| | 325×8,0-219×6,0 | 14 6821 0578 | 05 | 14 6821 4578 | 00 | 14 6821 4878 | 02 |
| | 325×10,0-219×8,0 | 14 6821 0580 | 00 | 14 6821 4580 | 06 | 14 6821 4879 | 01 |
| | 325×12,0-219×8,0 | 14 6821 0582 | 09 | 14 6821 4582 | 04 | 14 6821 4882 | 08 |
| 377×9,0-325×8,0 | 14 6821 0584 | 07 | 14 6821 4584 | 02 | 14 6821 4884 | 04 | |
| 377×12,0-325×10,0 | 14 6821 0586 | 05 | 14 6821 4586 | 00 | 14 6821 4886 | 02 | |
| 377×9,0-273×8,0 | 14 6821 0588 | 03 | 14 6821 4588 | 09 | 14 6821 4888 | 00 | |
| 377×12,0-273×10,0 | 14 6821 0590 | 09 | 14 6821 4590 | 04 | 14 6821 4890 | 06 | |
| 426×10,0-377×9,0 | 14 6821 0592 | 07 | 14 6821 4592 | 02 | 14 6821 4892 | 04 | |
| 426×16,0-377×12,0 | 14 6821 0594 | 05 | 14 6821 4594 | 00 | 14 6821 4894 | 02 | |
| 426×10,0-325×8,0 | 14 6821 0596 | 03 | 14 6821 4596 | 09 | 14 6821 4896 | 00 | |
| 426×16,0-325×10,0 | 14 6821 0598 | 01 | 14 6821 4597 | | 14 6821 4898 | 09 | |

2. Коды ОКП тройников для трубопроводов пара и горячей воды должны соответствовать указанным в [табл. 2](#).

Таблица 2

| Обозначение отводов | | Коды ОКП тройников для трубопроводов пара и горячей воды из стали | | | | | |
|---------------------------|-----------------|---|----|--------------|----|--------------|----|
| | | 20 | | 10Г2 | | 09Г2С | |
| | | Код ОКП | КЧ | Код ОКП | КЧ | Код ОКП | КЧ |
| Тройник равнопроходный | 45×2,5 | 14 6821 2000 | 01 | 14 6821 5000 | 00 | 14 6821 5300 | 02 |
| | 45×4,0 | 14 6821 2002 | 09 | 14 6821 5002 | 09 | 14 6821 5302 | 00 |
| | 57×3,0 | 14 6821 2004 | 08 | 14 6821 5004 | 07 | 14 6821 5304 | 09 |
| | 57×5,0 | 14 6821 2006 | 06 | 14 6821 5006 | 05 | 14 6821 5306 | 07 |
| | 76×3,5 | 14 6821 2008 | 04 | 14 6821 5008 | 03 | 14 6821 5308 | 05 |
| | 76×6,0 | 14 6821 2010 | 02 | 14 6821 5010 | 09 | 14 6821 5310 | 00 |
| | 89×3,5 | 14 6821 2012 | 08 | 14 6821 5012 | 07 | 14 6821 5312 | 09 |
| | 89×6,0 | 14 6821 2014 | 06 | 14 6821 5014 | 05 | 14 6821 5314 | 07 |
| | 108×4,0 | 14 6821 2016 | 04 | 14 6821 5016 | 03 | 14 6821 5316 | 05 |
| | 108×6,0 | 14 6821 2018 | 02 | 14 6821 5018 | 01 | 14 6821 5318 | 03 |
| | 108×8,0 | 14 6821 2019 | 01 | 14 6821 5020 | 07 | 14 6821 5320 | 09 |
| | 133×4,0 | 14 6821 2020 | 08 | 14 6821 5022 | 05 | 14 6821 5322 | 07 |
| | 133×6,0 | 14 6821 2022 | 06 | 14 6821 5024 | 03 | 14 6821 5324 | 05 |
| | 133×8,0 | 14 6821 2021 | 07 | 14 6821 5026 | 01 | 14 6821 5326 | 03 |
| | 159×4,5 | 14 6821 2024 | 04 | 14 6821 5028 | 06 | 14 6821 5328 | 01 |
| | 159×6,0 | 14 6821 2026 | 02 | 14 6821 5030 | 05 | 14 6821 5330 | 07 |
| | 159×8,0 | 14 6821 2028 | 00 | 14 6821 5032 | 03 | 14 6821 5332 | 05 |
| | 219×6,0 | 14 6821 2030 | 06 | 14 6821 5034 | 02 | 14 6821 5334 | 03 |
| | 219×8,0 | 14 6821 2032 | 04 | 14 6821 5036 | 03 | 14 6821 5336 | 01 |
| | 219×10,0 | 14 6821 2034 | 02 | 14 6821 5038 | 08 | 14 6821 5338 | 04 |
| | 273×8,0 | 14 6821 2036 | 00 | 14 6821 5040 | 03 | 14 6821 5340 | 05 |
| | 273×10,0 | 14 6821 2038 | 09 | 14 6821 5042 | 01 | 14 6821 5342 | 03 |
| | 273×12,0 | 14 6821 2040 | 04 | 14 6821 5044 | 10 | 14 6821 5344 | 01 |
| | 325×8,0 | 14 6821 2042 | 02 | 14 6821 5046 | 08 | 14 6821 5346 | 01 |
| | 325×10,0 | 14 6821 2044 | 00 | 14 6821 5048 | 06 | 14 6821 5348 | 08 |
| | 325×12,0 | 14 6821 2046 | 09 | 14 6821 5050 | 01 | 14 6821 5350 | 03 |
| | 377×9,0 | 14 6821 2048 | 07 | 14 6821 6052 | 08 | 14 6821 5352 | 01 |
| | 377×12,0 | 14 6821 2050 | 02 | 14 6821 5054 | 08 | 14 6821 5354 | 09 |
| | 426×10 | 14 6821 2052 | 00 | 14 6821 5056 | 06 | 14 6821 5356 | 08 |
| | 426×16 | 14 6821 2054 | 09 | 14 6821 5058 | 04 | 14 6821 5358 | 06 |
| Тройник переходный | 57×3,0-45×2,5 | 14 6821 2500 | 08 | 14 6821 5100 | 08 | 14 6821 5400 | 06 |
| | 57×5,0-45×4,0 | 14 6821 2502 | 06 | 14 6821 5102 | 06 | 14 6821 5402 | 08 |
| | 76×3,5-57×3,0 | 14 6821 2504 | 04 | 14 6821 5104 | 04 | 14 6821 5404 | 06 |
| | 76×6,0-57×5,0 | 14 6821 2506 | 02 | 14 6821 5106 | 02 | 14 6821 5406 | 04 |
| | 76×3,5-45×2,5 | 14 6821 2508 | 00 | 14 6821 5108 | 00 | 14 6821 5408 | 02 |
| | 76×6,0-45×4,0 | 14 6821 2510 | 06 | 14 6821 5110 | 06 | 14 6821 5410 | 08 |
| | 89×3,5-76×3,5 | 14 6821 2512 | 04 | 14 6821 5112 | 04 | 14 6821 5412 | 06 |
| | 89×6,0-76×6,0 | 14 6821 2514 | 02 | 14 6821 5114 | 02 | 14 6821 5414 | 04 |
| | 89×3,5-57×3,0 | 14 6821 2516 | 00 | 14 6821 5116 | 00 | 14 6821 5416 | 02 |
| | 89×6,0-57×4,0 | 14 6821 2518 | 09 | 14 6821 5118 | 09 | 14 6821 5418 | 00 |
| | 108×4,0-89×4,0 | 14 6821 2520 | 04 | 14 6821 5120 | 04 | 14 6821 5420 | 06 |
| | 108×6,0-89×6,0 | 14 6821 2522 | 02 | 14 6821 5122 | 02 | 14 6821 5422 | 04 |
| | 108×8,0-89×8,0 | 14 6821 2523 | 01 | 14 6821 5124 | 00 | 14 6821 5424 | 02 |
| | 108×4,0-76×3,5 | 14 6821 2524 | 00 | 14 6821 5126 | 09 | 14 6821 5426 | 00 |
| | 108×6,0-76×5,0 | 14 6821 2526 | 09 | 14 6821 5128 | 07 | 14 6821 5428 | 09 |
| | 108×8,0-76×8,0 | 14 6821 2527 | 08 | 14 6821 5130 | 02 | 14 6821 5430 | 04 |
| | 133×4,0-108×4,0 | 14 6821 2528 | 07 | 14 6821 5132 | 00 | 14 6821 5432 | 02 |
| | 133×6,0-108×5,0 | 14 6821 2530 | 02 | 14 6821 5134 | 09 | 14 6821 5434 | 00 |
| | 133×8,0-108×6,0 | 14 6821 2531 | 01 | 14 6821 5136 | 07 | 14 6821 5436 | 09 |
| | 133×4,0-89×3,5 | 14 6821 2532 | 00 | 14 6821 5138 | 05 | 14 6821 5438 | 07 |
| | 133×6,0-89×5,0 | 14 6821 2534 | 09 | 14 6821 5140 | 00 | 14 6821 5440 | 02 |
| | 133×8,0-89×6,0 | 14 6821 2535 | 08 | 14 6821 5141 | 10 | 14 6821 5411 | 01 |
| | 159×4,5-133×4,0 | 14 6821 2536 | 07 | 14 6821 5142 | 09 | 14 6821 5442 | 00 |
| | 159×6,0-133×5,0 | 14 6821 2538 | 05 | 14 6821 5144 | 07 | 14 6821 5444 | 09 |
| | 159×8,0-133×6,0 | 14 6821 2540 | 00 | 14 6821 5146 | 05 | 14 6821 5446 | 07 |
| | 159×4,5-108×4,0 | 14 6821 2542 | 09 | 14 6821 5148 | 03 | 14 6821 5448 | 05 |
| | 159×6,0-108×4,0 | 14 6821 2544 | 07 | 14 6821 5150 | 09 | 14 6821 5450 | 00 |

| Обозначение отводов | Коды ОКП тройников для трубопроводов пара и горячей воды из стали | | | | | |
|---------------------|---|----|--------------|----|--------------|----|
| | 20 | | 10Г2 | | 09Г2С | |
| | Код ОКП | КЧ | Код ОКП | КЧ | Код ОКП | КЧ |
| 159×8,0-108×5,0 | 14 6821 2546 | 05 | 14 6821 5152 | 07 | 14 6821 5452 | 09 |
| 219×6,0-159×4,5 | 14 6821 2548 | 03 | 14 6821 5154 | 05 | 14 6821 5454 | 01 |
| 219×8,0-159×6,0 | 14 6821 2550 | 09 | 14 6821 5156 | 03 | 14 6821 5456 | 05 |
| 219×10,0-159×8,0 | 14 6821 2552 | 07 | 14 6821 5158 | 01 | 14 6821 5458 | 03 |
| 219×6,0-133×4,0 | 14 6821 2554 | 05 | 14 6821 5160 | 07 | 14 6821 5460 | 09 |
| 219×8,0-133×5,0 | 14 6821 2556 | 03 | 14 6821 5162 | 05 | 14 6821 5462 | 07 |
| 219×10,0-133×8,0 | 14 6821 2558 | 01 | 14 6821 5164 | 03 | 14 6821 5464 | 05 |
| 273×8,0-219×6,0 | 14 6821 2560 | 07 | 14 6821 5166 | 01 | 14 6821 5466 | 03 |
| 273×10,0-219×8,0 | 14 6821 2562 | 05 | 14 6821 5168 | 09 | 14 6821 5468 | 01 |
| 273×12,0-219×10,0 | 14 6821 2564 | 03 | 14 6821 5170 | 05 | 14 6821 5470 | 07 |
| 273×8,0-159×4,5 | 14 6821 2566 | 01 | 14 6821 5172 | 03 | 14 6821 5472 | 05 |
| 273×10,0-159×6,0 | 14 6821 2568 | 00 | 14 6821 5174 | 01 | 14 6821 5474 | 03 |
| 273×12,0-159×8,0 | 14 6821 2570 | 05 | 14 6821 5176 | 06 | 14 6821 5476 | 01 |
| 325×8,0-273×7,0 | 14 6821 2572 | 03 | 14 6821 5178 | 08 | 14 6821 5478 | 07 |
| 325×10,0-273×13,0 | 14 6821 2574 | 01 | 14 6821 5180 | 03 | 14 6821 5480 | 05 |
| 325×12,0-273×10,0 | 14 6821 2576 | 08 | 14 6821 5182 | 01 | 14 6821 5482 | 03 |
| 325×8,0-219×6,0 | 14 6821 2578 | 08 | 14 6821 5184 | 03 | 14 6281 5484 | 01 |
| 325×10,0-219×8,0 | 14 6821 2580 | 03 | 14 6821 5186 | 08 | 14 6821 5486 | 04 |
| 325×12,0-219×8,0 | 14 6821 2582 | 01 | 14 6821 5188 | 06 | 14 6821 5488 | 08 |
| 377×9,0-325×8,0 | 14 6821 2584 | 05 | 14 6821 5190 | 01 | 14 6821 5490 | 03 |
| 377×12,0-325×10,0 | 14 6821 2586 | 08 | 14 6821 5192 | 10 | 14 6821 5492 | 01 |
| 377×9,0-273×8,0 | 14 6821 2588 | 06 | 14 6821 5194 | 08 | 14 6821 5494 | 01 |
| 377×12,0-273×10,0 | 14 6821 2690 | 01 | 14 6821 5196 | 06 | 14 6821 5496 | 08 |
| 426×10,0-377×9,0 | 14 6821 2592 | 02 | 14 6821 5198 | 04 | 14 6821 5498 | 06 |
| 426×16,0-377×12,0 | 14 6821 2594 | 08 | 14 6821 5200 | 05 | 14 6821 5500 | 07 |
| 426×10,0-325×8,0 | 14 6821 2596 | 06 | 14 6821 5202 | 03 | 14 6821 5502 | 05 |
| 426×16,0-325×10,0 | 14 6821 2598 | 04 | 14 6821 5204 | 01 | 14 6821 5504 | 03 |

(Измененная редакция, Изм. № 1).